



SPRING

SERVE OVER DELI COUNTER

FEATURES INCLUDE:

Curved lift up glass
825mm deep display
Front glass demister
Canopy lighting inc switch
Refrigerated storage under

Rear perspex slides
Electronic temperature control
Condensation removal via
hot gas discharge
Castor wheels (optional)
Non-refrigerated internal shelf
(optional)



SPRING

SERVE OVER DELI COUNTER

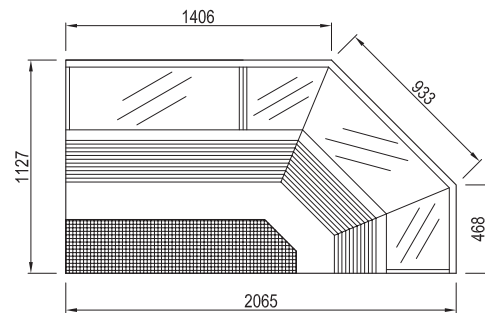
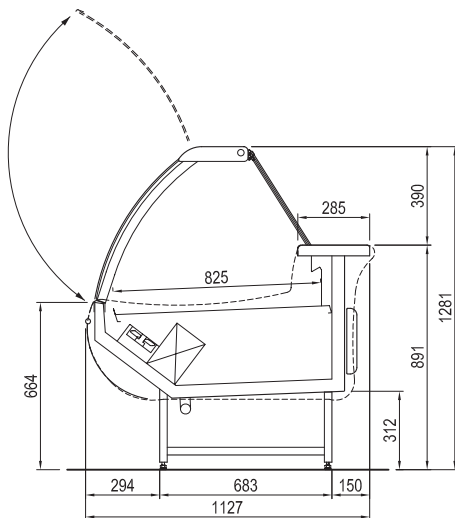

SPRING R/H CNR

SPRING	1250	1563	1875	2500	3125	3750	90° R/H cnr
* Operating temp (°C)	0/+2	0/+2	0/+2	0/+2	0/+2	+2/+4	0/+2
Refrigeration	Ventilated	Ventilated	Ventilated	Ventilated	Ventilated	Ventilated	Ventilated
Defrost	Automatic	Automatic	Automatic	Automatic	Automatic	Automatic	Automatic
Power requirements	1ph / 10amp	1ph / 10amp	1ph / 10amp	1ph / 10amp	1ph / 10amp	1ph / 10amp	1ph / 10amp
Nominal power (W)	496	630	767	810	1046	1163	816
Display area (m2)	1.09	1.39	1.58	2.18	2.67	3.17	1.88
Length w/o endwalls (mm)	1250	1562.5	1875	2500	3125	3750	Refer to layout
Endwall width (mm)	50	50	50	50	50	50	50
Height w/o castors (mm)	1281	1281	1281	1281	1281	1281	1281
Height inc castors (mm)	1361	1361	1361	1361	1361	1361	1361
Weight w/o packaging (kg)	150	180	210	270	340	400	220

* Climate class 3 (25°C 60%R/H)

Information supplied as a guide only and is subject to change without notice.

Head office - WA
6 Parkland Road
Osborne Park WA 6017
Phone 08.9242.5000
Fax 08.9242.5055

Darra - QLD Branch
24 Sudbury Street
DARRA QLD 4076
Phone 07.3715.8812
Fax 07.3715.8867

Bunbury - WA Branch
Unit 2,3 Halifax Drive
BUNBURY WA 6230
Phone 08.9726.0500
Fax 08.9726.0400

BAKER