



CHEST FREEZER

SOUND

FEATURES INCLUDE:

- Skin evaporator
- Sliding curved glass lids
- Alarm warning lamp
- Electronic temperature control
- Perimeter skin condenser
- External Light box (optional)
- Dual temperature version available - (ex factory)

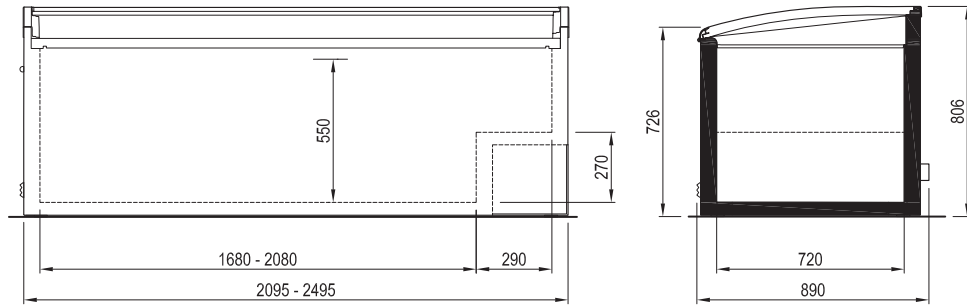
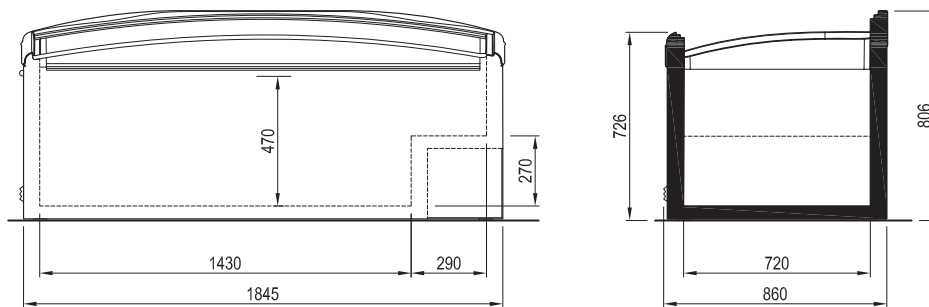

SOUND

Sound Linear 2100 / Linear 2500

Sound TG 1850

SOUND	2100	2500	TG 1850
* Operating temp (°C)	-18	-18	-18
Refrigeration	Static	Static	Static
Defrost	Manual	Manual	Manual
Power requirements	1ph / 10amp	1ph / 10amp	1ph / 10amp
Nominal power (W)	415	430	390
Display surface (m2)	1.41	1.7	1.23
Storage capacity @ lower load height (L)	720	724	625
Storage capacity @ upper load height (L)	865	870	621
Length including bumper (mm)	1570	2070	2570
Height w/o castors (mm)	806	806	806
Height inc castors (mm)	876	876	876
Weight w/o packaging (kg)	120	138	110
M.E.P.S. rating	4L1	4L1	4L1

* Climate class 3 (25°C 60% R/H) @ upper load height
Climate class 4 (30°C 55% R/H) @ lower load height

Note

lower load height: 520mm (2100/2500 case), 440mm (TG 1850)
upper load height: 550mm (2100/2500 case), 470mm (TG 1850)

Information supplied as a guide only and is subject to change without notice.

Head office - WA
6 Parkland Road
Osborne Park WA 6017
Phone 08.9242.5000
Fax 08.9242.5055

Darra - QLD Branch
24 Sudbury Street
DARRA QLD 4076
Phone 07.3715.8812
Fax 07.3715.8867

Bunbury - WA Branch
Unit 2,3 Halifax Drive
BUNBURY WA 6230
Phone 08.9726.0500
Fax 08.9726.0400