



ISLAND DUAL TEMPERATURE

PEAK

FEATURES INCLUDE:

Dual temperature
2 x glass sides (double-glazed),
2 x solid ends
Interior light & switch

Ambient air screen to glass sides
Temperature selector switch
Castor wheels
Night covers



PEAK

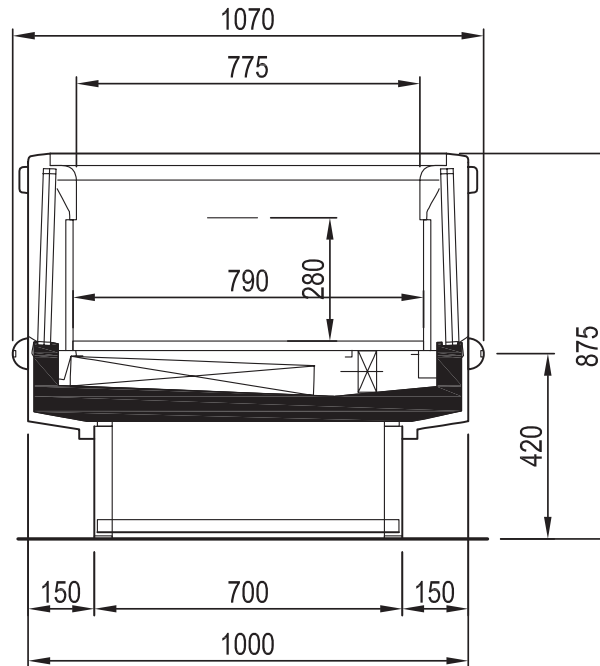

PEAK	**150	200
* Operating temp (°C)	0/+2 & -18/-24	0/+2 & -18/-24
Refrigeration	Ventilated	Ventilated
Defrost	Automatic	Automatic
Power requirements	1ph / 15amp	1ph / 15amp
Nominal power (W)	970	1350
Defrosting power (W)	2300	3000
Lighting power (W)	2 x 36	2 x 58
Display surface (m ²)	1.81	2.46
Net capacity (L)	303	413
Length including bumper (mm)	1570	2070
Height w/o castors (mm)	875	875
Height inc castors (mm)	945	945
Weight w/o packaging (kg)	215	315
M.E.P.S rating	3L1 (Low temp) 3M1 (Medium temp)	3L1 (Low temp) 3M1 (Medium temp)

* Climate Class 3 (25°C 60% R/H)

** ex factory item

Information supplied as a guide only and is subject to change without notice.

Head office - WA
6 Parkland Road
Osborne Park WA 6017
Phone 08.9242.5000
Fax 08.9242.5055

Darra - QLD Branch
24 Sudbury Street
DARRA QLD 4076
Phone 07.3715.8812
Fax 07.3715.8867

Bunbury - WA Branch
Unit 2,3 Halifax Drive
BUNBURY WA 6230
Phone 08.9726.0500
Fax 08.9726.0400