

# CRIOCABIN

# EXPRESS EX100

SERVE OVER DELI COUNTER

**FEATURES INCLUDE:**

Curved lift up glass  
830mm deep display  
Canopy lighting  
Refrigerated storage under  
Rear perspex slides  
Electronic temperature control

Castor wheels (optional)  
Refrigerated corners  
(optional-ex factory)  
Non-refrigerated internal shelf  
(optional)



## EXPRESS EX100

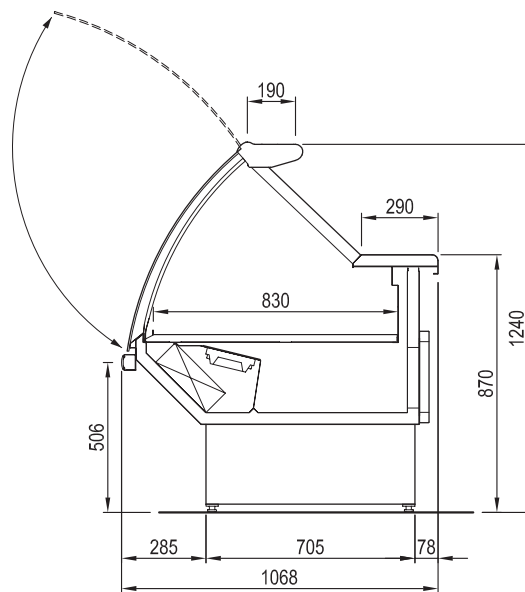

EXPRESS EX100	1250	1875	2500	** 3750
* Operating temp (°C)	+2/+4	+2/+4	+2/+4	+2/+4
Refrigeration	Ventilated	Ventilated	Ventilated	Ventilated
Defrost	Automatic	Automatic	Automatic	Automatic
Power requirements	1ph / 10amp	1ph / 10amp	1ph / 10amp	1ph / 10amp
Nominal power (W)	500	800	850	1200
Display area (m2)	1.04	1.56	2.08	3.11
Length w/o endwalls (mm)	1250	1875	2500	3750
Endwall width (mm)	55	55	55	55
Height w/o castors (mm)	1240	1240	1240	1240
Height inc castors (mm)	1320	1320	1320	1320
Weight w/o packaging (kg)	150	210	270	400

\* Climate class 3 (25°C 60%R/H)

\*\* ex factory item

Information supplied as a guide only and is subject to change without notice.

**Head office - WA**  
6 Parkland Road  
Osborne Park WA 6017  
Phone 08.9242.5000  
Fax 08.9242.5055

**Darra - QLD Branch**  
24 Sudbury Street  
DARRA QLD 4076  
Phone 07.3715.8812  
Fax 07.3715.8867

**Bunbury - WA Branch**  
Unit 2,3 Halifax Drive  
BUNBURY WA 6230  
Phone 08.9726.0500  
Fax 08.9726.0400