



COLD
ENGINEERING
TECFRIGO

COUNTER TOP PATISSERIE DISPLAY

DOMINANTE

FEATURES INCLUDE:

- Double glazing
- Adjustable height wire shelves
- Internal lighting inc switch
- Sliding glass doors
- Electronic temperature control





COLD
ENGINEERING
TECFRIGO

DOMINANTE

COUNTER TOP PATISSERIE DISPLAY

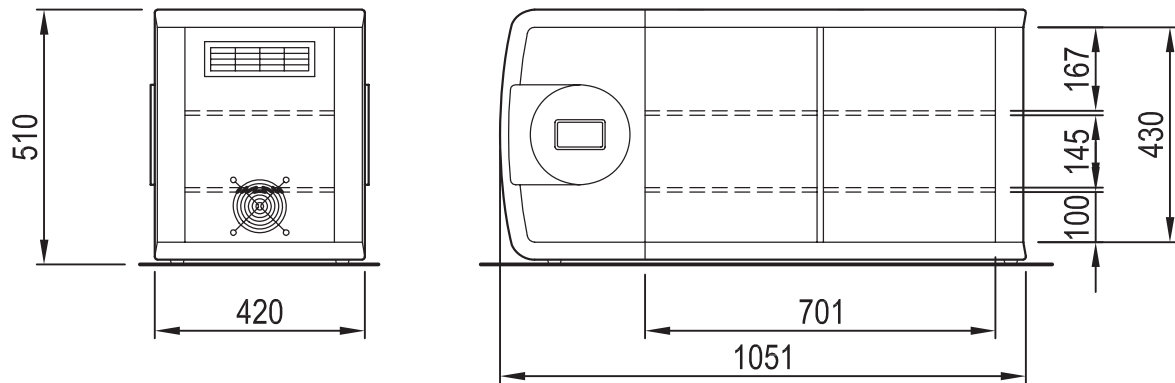

DOMINANTE	100G
* Operating temp (°C)	+4/+10
Refrigeration	Ventilated
Defrost	Manual
Power requirements	1ph / 10amp
Nominal power (W)	260
Humidity (%)	80
Capacity (L)	100
Shelf dimensions (mm)	710 x 320 (x2)
Weight w/o packaging (kg)	42
M.E.P.S rating	3M2

* Climate class 3 (25°C, 60%R/H)

Information supplied as a guide only and is subject to change without notice.

Head office - WA
6 Parkland Road
Osborne Park WA 6017
Phone 08.9242.5000
Fax 08.9242.5055

Darra - QLD Branch
24 Sudbury Street
DARRA QLD 4076
Phone 07.3715.8812
Fax 07.3715.8867

Bunbury - WA Branch
Unit 2,3 Halifax Drive
BUNBURY WA 6230
Phone 08.9726.0500
Fax 08.9726.0400

BAKER