

# SF-Series 900 Flake Ice Machine



**Manitowoc**



SF-Series 900  
Flake Ice Machine  
on B-570 Bin

- Up to 929 lbs. (421 kgs.) daily ice production
- Only 22" (55.88 cm) wide
- Flake ice is small hard bits of ice ideally suited for any "contact" presentation. It forms completely around the contact item and cools quickly
- Manitowoc's patented cleaning technology manages the cleaning process from start to finish
- Evaporator is designed for maximum quality and operating life
- Warranty  
2-year parts and labor coverage on all components. Additional 3-year (5-year total) parts coverage on ice machine compressor



ISO 9001:2000  
Quality System  
Certified

**America's #1 Selling Ice Machine**

Cube, Nugget & Flake Ice Machines • Ice Storage Bins • Ice Dispensers

**Manitowoc**  
Foodservice Group

# SF-Series 900 Flake Ice Machine

## Space-Saving Designs



	SF-900 B-420	SF-900 B-570
Height	76.50" 194.31 cm	76.50" 194.30 cm
Width	22.00" 55.88 cm	30.00" 76.20 cm
Depth	34.00" 86.30 cm	34.00" 86.30 cm
Bin Storage	310 lbs. 141 kgs.	430 lbs. 195 kgs.

B-570 requires K-00365 adapter.

Height includes adjustable bin legs 6.00" to 7.00", (15.24 to 17.78 cm) set at 6.00" (15.24 cm).

Model	Ice Shape	Ice Production 24 Hours Based on Air/Water Temp.				Power kWh/100 lbs.
		70°/50°F		90°/70°F		
SF-0906A	Flake	929 lbs.	421 kgs.	744 lbs.	337 kgs.	4.0
SF-0907W	Flake	983 lbs.	445 kgs.	853 lbs.	387 kgs.	3.2
Water Usage/100 lbs./45.4 kgs. of Ice						
Potable Water: 12 Gallons, 45.4 Liters • Water-cooled Condenser: 116 Gallons, 439 Liters						

Order ice storage bin separately. "A", or "W" following model number indicates

"Air", or "Water" condensing unit. Will not accept AuCS accessory.

Test conditions are 90°F/32°C air, 70°F/21°C water, and 30 ± 3 psig water inlet pressure.

## Ice Machine Electric

208-230/60/1. (230/50/1 also available, consult factory.)

**Minimum circuit ampacity:** Air-cooled: 8 amps  
Water-cooled: 7.7 amps

**Maximum fuse size:** Air, and Water cooled: 15 amps

HACR-type circuit breakers can be used in place of fuses.

## Specifications

### BTU Per Hour:

9,000 (average) 14,000 (peak)

### Compressor:

Nominal rating: 2 HP

Refrigerant: R404A

### Cupra-Nickel Condenser:

(Water-cooled models)

Adds protection from corrosive water elements.

### Operating Limits:

• Ambient Temperature Range:

45°-110°F (7.2°-43.3°C)

• Water Temperature Range:

45°-90°F (7.2°-32.2°C)

• Water Pressure Ice Maker

Water In:

Min. 20 psi (137.9 kPa)

Max. 80 psi (551.1 kPa)

## Ice Shape

Flake ice is small hard bits of ice ideally suited for presentation applications.



## SF-900 on B-570 Storage Bin

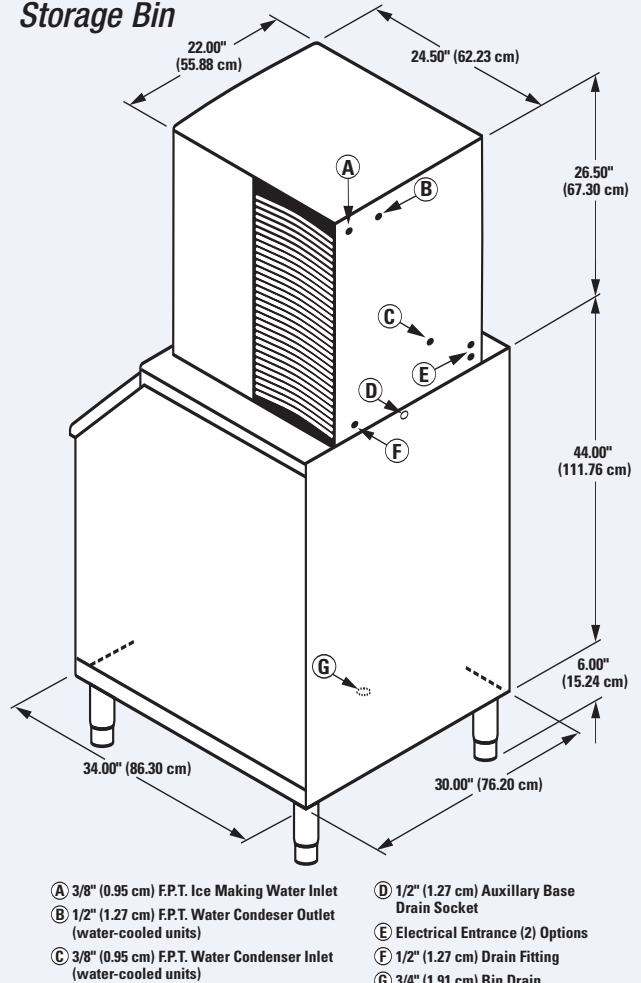

©2007 Manitowoc. 5/07 Continuing product improvement may necessitate change of specifications without notice. 3973

## Installation Note -

Minimum installation clearance— Top/sides: 8" (20.32 cm); Back: is 5" (12.7 cm).



**Manitowoc**

MANITOWOC ICE, INC.  
2110 South 26th Street, P.O. Box 1720  
Manitowoc, WI 54221-1720, USA  
Ph: 920-682-0161 • Fax: 920-683-7589  
Visit us online at [www.manitowocice.com](http://www.manitowocice.com)

