

SF-Series 1200 Flake Ice Machine



NEW



SF-Series 1200
Flake Ice Machine
on B-570 Bin

- Up to 1220 lbs. (553 kgs.) daily ice production
- Only 30" (76.2 cm) wide
- Flake ice is small hard bits of ice ideally suited for any "contact" presentation. It forms completely around the contact item and cools quickly
- Manitowoc's patented cleaning technology manages the cleaning process from start to finish
- Evaporator is designed for maximum quality and operating life
- Warranty
2-year parts and labor coverage on all components. Additional 3-year (5-year total) parts coverage on ice machine compressor



ISO 9001:2000
Quality System
Certified

America's #1 Selling Ice Machine

Cube, Nugget & Flake Ice Machines • Ice Storage Bins • Ice Dispensers

Manitowoc
Foodservice Group

SF-Series 1200 Flake Ice Machine

Space-Saving Designs

SF-1200
B-570



Height	80.00" 203.00 cm
Width	30.00" 76.2 cm
Depth	34.00" 86.30 cm
Bin Storage	430 lbs. 195 kgs.

Height includes adjustable bin legs 6.00" to 7.00", (15.24 to 17.78 cm) set at 6.00" (15.24 cm).

Model	Ice Shape	Ice Production 24 Hours Based on Air/Water Temp.				Power kWh/100 lbs. 90°/70°F
		70°/50°F		90°/70°F		
SF-1206A	Flake	1220 lbs.	553 kgs.	1018 lbs.	462 kgs.	3.80
SF-1207W	Flake	1272 lbs.	577 kgs.	1105 lbs.	501 kgs.	3.23
Water Usage/100 lbs./45.4 kgs. of Ice						
Potable Water: 12 Gallons, 45.4 Liters • Water-cooled Condenser: 116 Gallons, 439 Liters						

Order ice storage bin separately. "A", or "W" following model number indicates "Air", or "Water" condenser.

Will not accept AUCS accessory.

Test conditions are 90°F/32°C air, 70°F/21°C water, and 30 ± 3 psig water inlet pressure.

Ice Machine Electric

208-230/60/1. (208-230/60/3 and 230/50/1 also available, consult factory.)

Minimum circuit ampacity:	Air-cooled:	9.8 amps	1ph
		7.6 amps	3ph
	Water-cooled:	9.0 amps	1ph
		6.8 amps	3ph

Maximum fuse size:	Air- and Water-cooled:	15 amps	1ph
		15 amps	3ph

HACR-type circuit breakers can be used in place of fuses.

Specifications

BTU Per Hour:

15,000 (average) 22,000 (peak)

Compressor:

Nominal rating: 1.75 HP

Refrigerant: R404A

Cupra-Nickel Condenser:

(Water-cooled models)
Adds protection from
corrosive water elements.

Operating Limits:

- Ambient Temperature Range:
45°-110°F (7.2°-43.3°C)
- Water Temperature Range:
45°-90°F (7.2°-32.2°C)
- Water Pressure Ice Maker
Water In:
Min. 20 psi (137.9 kPA)
Max. 80 psi (551.1 kPA)

Ice Shape

Flake ice is small hard bits
of ice ideally suited for
presentation
applications.



SF-1200 on B-570 Storage Bin

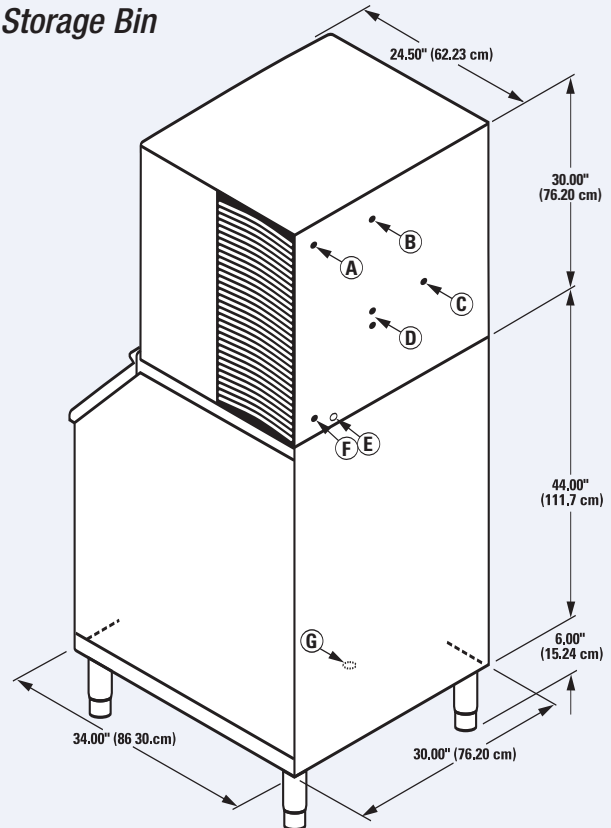

Installation Note -

Minimum installation clearance— Top/sides: 8" (20.32 cm); Back: is 5" (12.7 cm).

Note - Not approved for dispenser applications.

©2007 Manitowoc 6107 Continuing product improvement may necessitate change of specifications without notice. 3992

MANITOWOC ICE, INC.
2110 South 26th Street, P.O. Box 1720
Manitowoc, WI 54221-1720, USA
Ph: 920-682-0161 • Fax: 920-683-7589
Visit us online at www.manitowocice.com

